

NOTE:
 FIELD CUT FIRST
 AND LAST PANELS
 TO EQUAL WIDTH.

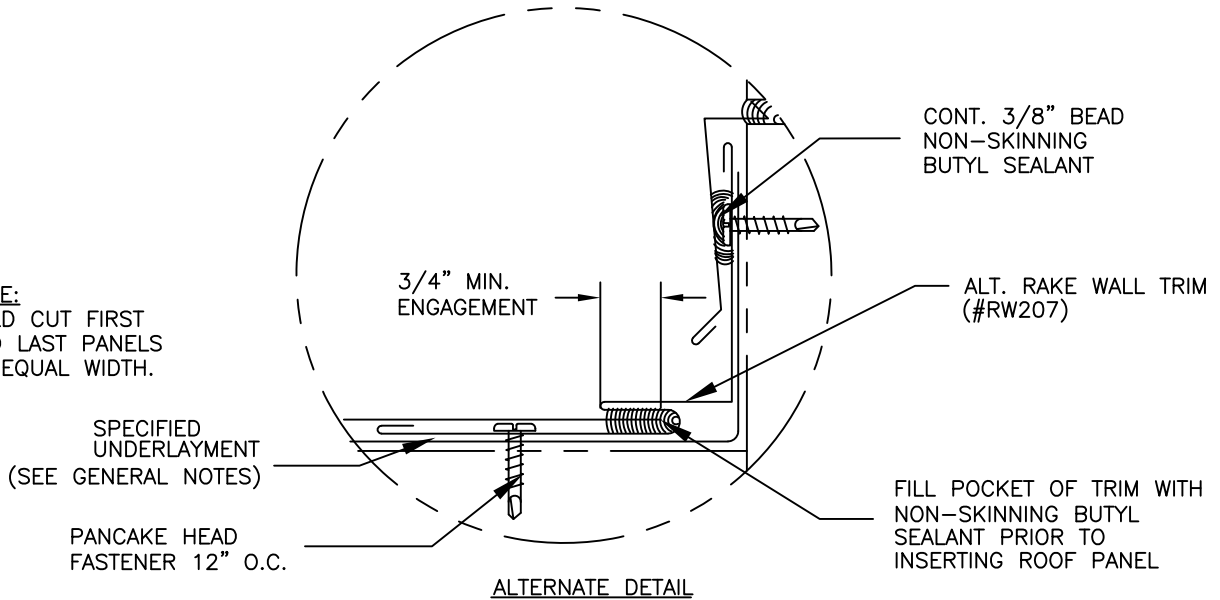

SELECT SEAM
 NARROW BATTEN

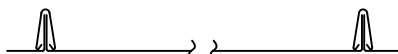

SIDE WALL
 (RAKE WALL)

SSNB-08